

Features

- ✧ Fault checking on the power.
- ✧ Cable checking on the intrinsically safe loop.
- ✧ Metal cabinet, high water-proof and anti-interference abilities.
- ✧ “S”, “G” can activate sounder/sounder strobe externally.

Description

I-9333 Interface can connect with C-9404(Ex) Sounder and C-9403(Ex) Sounder Strobe in explosion-proof system. Receiving the start command from fire alarm control panel or the closed contact signal from “S”, “G”, I-9333 Interface will activate explosion-proof devices in field and transmits the action information to the fire alarm control panel.

When 24VDC power fault or connection fault between the interface and field sounder or sounder strobe occurs, it will send fault signal to fire alarm control panel and illuminate Fault LED.

Built-in safety barrier, it is a relative device to restrict the energy to the explosive environment.

Connection and Wiring

Cable Size

The 1.0mm² or above intrinsically safe cable is used to connect safety barrier and explosion proof sounder/sounder strobe, the capacitance distributed among cables should not be over 0.083μ F, and the inductance distributed should not be over 4mH. The color of cables should be different to distinct polarity.

1.0mm² or above copper cable with φ 8mm~φ 10mm outer diameter for Z1, Z2, D1, D2, S, and G.

φ 8mm~φ 10mm cable should be adopted in the places requiring water-proof. If twisted pair or solid wire has to be used, twine thread seal tape around the cable going through the Cable Entry to φ 8mm~φ 10mm.

Terminals

“Intrinsically safe” side includes terminal 3(+), 4(-) of safety barrier. 3(+) connects with D1 of explosion proof sounder/sounder strobe, and 4(-) connects with D2. Please note polarity.

Note: Must connect the wire correctly otherwise the interface won't alarm.

“Non intrinsically safe” side include six terminals. Z1, Z2 connects with the polarity-insensitive loop of fire alarm control panel, D1, D2 with polarity-insensitive 24VDC power line and S, G with controlling input contact.

In addition, the enclosure of the interface must connect to Ground securely, the bolt is as shown in Fig. 1.

Installation

Two mounting methods: One is mounted on the wall, and the other is mounted on the rack.

a) Wall mounted: Fix the mounting bracket to the wall using two M6×60 expansion bolts, its mounting dimension is shown in Fig. 2.

b) Rack mounted: Remove the mounting bracket from the

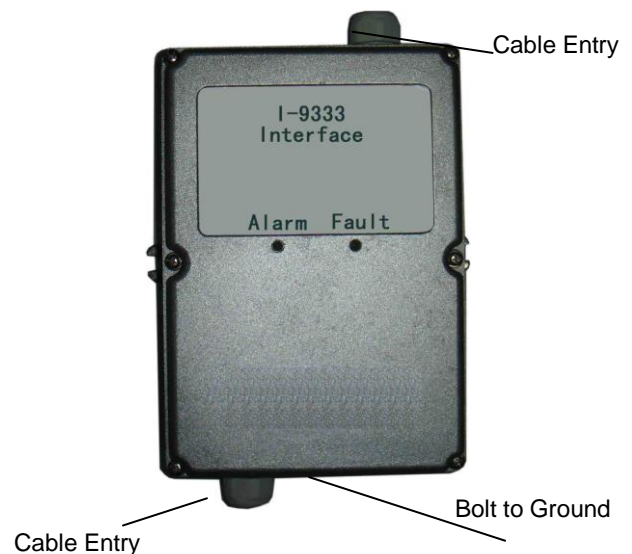

Fig. 1

back of the interface, then install the interface to the rack using M4×10 bolts, see Fig. 3.

Warning: This interface should be mounted in safety area. The wire of the interface from “Non-intrinsically safe” and those from “Intrinsically safe” should be separated from each other and be kept a certain distance (at least 50mm). Strictly follow the relative explosion-proof code when installing.

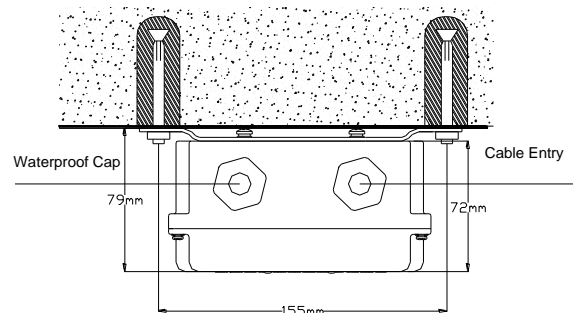

Fig. 2

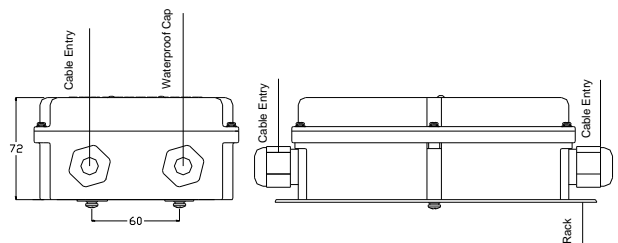

Fig. 3

Note: Horizontal mounting can protect water penetrating inside of the interface along the lead.

Application

I-9333 Interface can connect with explosion-proof sounder/sounder strobe to form explosion-proof system in fire alarm system. Its wiring diagram is shown in Fig. 4.

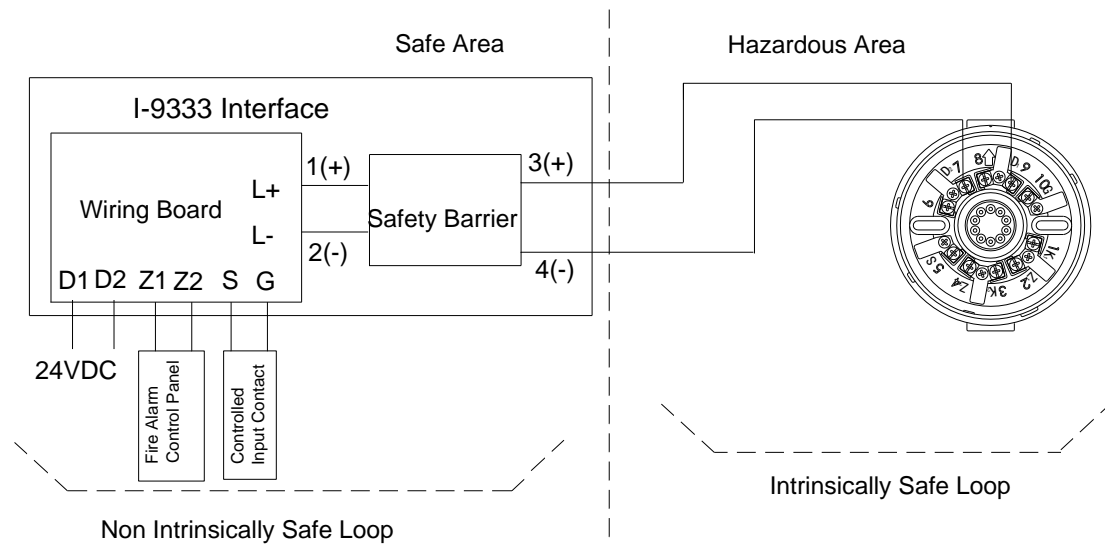

Fig. 4

Specification

Operating Voltage	Loop voltage: 24V Power voltage: 24VDC
Loop Current	Standby current $\leq 0.5\text{mA}$ Action current $\leq 5\text{mA}$
Power Current	Alarm current $\leq 5\text{mA}$
Output Capacity	60mA, to one explosion-proof sounder
Addressing	Occupying one address
Address Range	Selectable within 1~242
Ingress Protection Rating	IP65
Output Control	Electric level
LED	Alarm: Red Fault: Yellow
Environmental Temperature	$-10^{\circ}\text{C} \sim +50^{\circ}\text{C}$
Relative Humidity	$\leq 95\%$, non condensing
Dimension	201 mm \times 172 mm \times 79 mm
Material and Color of Enclosure	Cast aluminum alloy, silver grey
Weight	1kg
Mounting Hole Spacing	155mm or 60mm
Safety Barrier Parameter	$U_0=28\text{V}$, $I_0=93\text{mA}$, $L_0=4\text{mH}$, $C_0=0.083\mu\text{F}$
Wiring	Connecting with fire alarm control panel through polarity-insensitive loop, with 24VDC power line through polarity-insensitive loop.

Accessory and Tools

Model	QTY.	Remark
P-9910B Hand Held Programmer	1	Supplied separately

Limited Warranty

GST warrants that the product will be free from defects in design, materials and workmanship during the warranty period. This warranty shall not apply to any product that is found to have been improperly installed or used in any way not in accordance with the instructions supplied with the product. Anybody, including the agents, distributors or employees, is not in the position to amend the contents of this warranty. Please contact your local distributor for products not covered by this warranty.

This Data Sheet is subject to change without notice. Please contact GST for more information or questions.

Gulf Security Technology Co., Ltd.

No. 80, Changjiang East Road, QETDZ, Qinhuangdao, Hebei, P. R. China 066004

Tel: +86 (0) 335 8502434 Fax: +86 (0) 335 8502532

service.gst@fs.utc.com www.gst.com.cn